

# PER4MAX LYNX

Name: \_\_\_\_\_  
 Address: \_\_\_\_\_  
 City: \_\_\_\_\_  
 State: \_\_\_\_\_ Zip: \_\_\_\_\_  
 Email: \_\_\_\_\_

Date: \_\_\_\_\_ SSN# : \_\_\_\_\_ - \_\_\_\_\_ - \_\_\_\_\_  
 Age: \_\_\_\_\_ Weight (lbs.): \_\_\_\_\_ Height: \_\_\_\_\_' \_\_\_\_\_"  
 Disability: \_\_\_\_\_  
 Tel #: ( ) \_\_\_\_\_ - \_\_\_\_\_ (Home or Work)  
 Other Info: \_\_\_\_\_

## FRAME SPECIFICATION

### Model

LYNX ..... Retail: \$2495

#### 1) Seat Width

12"  13"  14"  15"  16"  17"  18"

Optional Tapered @ the Knee \_\_\_\_\_" ..... \$125

#### 2) Seat Depth

12"  13"  14"  15"  16"  17"  18"

#### 2a) Total Length \_\_\_\_\_"

#### 3) Front Style (front end)

"Y" Std. Style ..... NC

"V" Style ..... \$210

#### 4) Rear Seat Height

14"  15"  16"  17"  18"  Other \_\_\_\_\_"

Optional Plastic Seat Plate ..... \$125

#### 5) Front Seat Height

14"  15"  16"  17"  18"  Other \_\_\_\_\_"

#### 6) Backrest Height

10"  12"  14"  16"  Other: \_\_\_\_\_"

Back Height Adj. : From \_\_\_\_\_" to \_\_\_\_\_" ..... \$80

#### 7) Back Angle

0°  3°  5°  Other: \_\_\_\_\_° (⊥ Seat or ⊥ Floor)

#### 8) Foot Width

7"  8"  9"  10"  Other: \_\_\_\_\_"

#### 9) Lower Leg Length \_\_\_\_\_" (16", 17", etc.)

#### 10) Backrest To Center Axle

2"  3"  4"  5"  Other: \_\_\_\_\_"

#### 11) Center Axle To Caster Housing

15"  16"  17"  18"  Other: \_\_\_\_\_"

#### 12) Caster Housing To Front Foot Plate

1"  2"  3"  4"  Other: \_\_\_\_\_"

#### 13) Center of Caster to Caster

12"  14"  16"  18"  Other: \_\_\_\_\_"

#### 14) Side Wheel Clearance

1/2"  1"  1 1/2"  2"

#### 15) Camber Angle

12°  15°  17°  Other: \_\_\_\_\_°

## Notes:

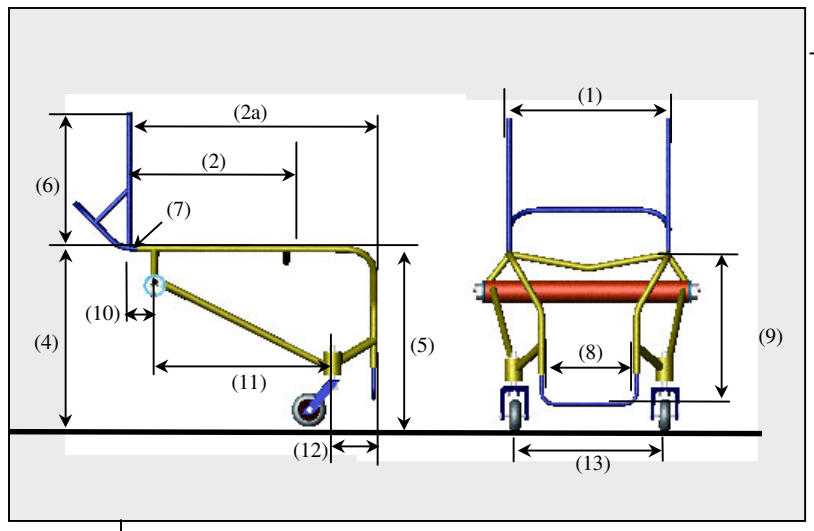

\*Effective: January 2007 Rev C.

Pricing and specifications are subject to change without notice

Customer Services: Telephone: 972-641-6773 Facsimile: 972-623-0585	PER4MAX MEDICAL www.per4max.com Page 1 of 2	612 N. Great Southwest Pkwy Arlington, TX 76011
--	---	--

# PER4MAX LYNX

## FRAME COLORS

- Sky White     Bonded Silver     Dormant Violet     Ruby Red     Glossy Black     Safety Yellow  
 Candy Blue     Sparkle Green     Safety Orange  
 Other: \_\_\_\_\_ \$TBD  
 Accessory Colors Standard Glossy Black     Accessory Color Option \_\_\_\_\_ (one color additional: \$350)  
 Backrest     Footrest     Removable 5th Wheel     Side Guards

## WHEELCHAIR OPTIONS

### 5th WHEEL

- Rigid ..... NC  
 Removable ..... \$250

### CLICK STRAP

- Waist Strap Size \_\_\_\_\_" ..... \$100  
 Lap Strap Size \_\_\_\_\_" ..... \$75

### BACK REST

- Rigid ..... NC  
 Continues ..... \$280

### SIDE GUARDS (std. fixed)

- Aluminum ..... \$140

### CASTERS

- 3" (72mm) Micro ..... NC  
 56mm Micro ..... \$60  
 Other \_\_\_\_\_ \$TBD

### MISCELLANEOUS

- Spoke Guards ..... \$100  
 Foam Impact Guards ..... \$75  
 Special Upholstery ..... \$180  
 Other \_\_\_\_\_ \$TBD

## WHEELS & TIRES

### WHEELS

- Rear Wheels ..... NC  
      24" **STD.**  
      25"     26"     27" ..... \$300  
 Spinergy Wheels ..... \$695  
      24"     25"     26"     27"  
      Black     White     Blue     Red     Yellow  
      Spinergy Sport Light Extreme (SLX).....add \$200

### HAND RIMS SYLE

- Hard Anodized 6 tab ..... NC  
 Hard Anodized 12 tab..... \$95  
 Rhino Coated ..... \$150  
 Other \_\_\_\_\_ \$TBD

### TIRES

- High Pressure Tires ..... NC  
 Tufo High Press. Tires ..... \$120  
 Other \_\_\_\_\_ \$TBD

Notes:

\*Effective: January 2007 Rev C.

Pricing and specifications are subject to change without notice

Customer Services: Telephone: 972-641-6773 Facsimile: 972-623-0585	<b>PER4MAX MEDICAL</b> www.per4max.com Page 2 of 2	612 N. Great Southwest Pkwy Arlington, TX 76011
--	--	--