

# PER4MAX LIGHTNING

Name: \_\_\_\_\_  
 Address: \_\_\_\_\_  
 City: \_\_\_\_\_  
 State: \_\_\_\_\_ Zip: \_\_\_\_\_  
 Email: \_\_\_\_\_

Date: \_\_\_\_\_ SSN# : \_\_\_\_\_ - \_\_\_\_\_ - \_\_\_\_\_  
 Age: \_\_\_\_\_ Weight (lbs.): \_\_\_\_\_ Height: \_\_\_\_\_' \_\_\_\_\_"  
 Disability: \_\_\_\_\_  
 Tel #: ( ) \_\_\_\_\_ - \_\_\_\_\_ (Home or Work)  
 Other Info: \_\_\_\_\_

## FRAME SPECIFICATION

**Model**

LIGHTNING ..... Retail: \$2495

**1) Seat Width**

- 12"  13"  14"  15"  16"  17"  18"

**2) Seat Depth**

- 12"  13"  14"  15"  16"  17"  18"

**2a) Total Length \_\_\_\_\_"**

**3) Front Style (front end)**

- "Y" Style ..... NC  
 "V" Style .....(requires a rotating footrest) \$ 210

**4) Rear Seat Height**

- 16"  17"  18"  19"  20"  21"

**5) Front Seat Height**

- 16"  17"  18"  19"  20"  21"

**6) Backrest Height**

- 10"  12"  14"  16"  Other: \_\_\_\_\_"  
 Back Height Adj.: From \_\_\_\_\_" to \_\_\_\_\_" ..... \$ 80

**7) Back Angle**

- 0°  3°  5°  Other: \_\_\_\_\_°

**8) Foot Width**

- 8"  9"  10"  11"  Other: \_\_\_\_\_"

**9) Lower Leg Length \_\_\_\_\_"** (16", 17", etc.)

**10) Backrest To Center Axle**

- 0"  1"  2"  3"  Other: \_\_\_\_\_"

**11) Center Axle To Caster Housing**

- 14"  15"  16"  17"  Other: \_\_\_\_\_"

**12) Caster Housing To Front Foot Plate**

- 3"  4"  5"  6"  Other: \_\_\_\_\_"

**13) Center of Caster to Caster**

- 12"  14"  16"  18"  Other: \_\_\_\_\_"

**14) Side Wheel Clearance**

- 1/2"  1"  1 1/2"  2"

**15) Camber Angle**

- 0°  3°  6°  Other: \_\_\_\_\_°

Extra: \_\_\_\_\_° (Add \$195)

## Notes:

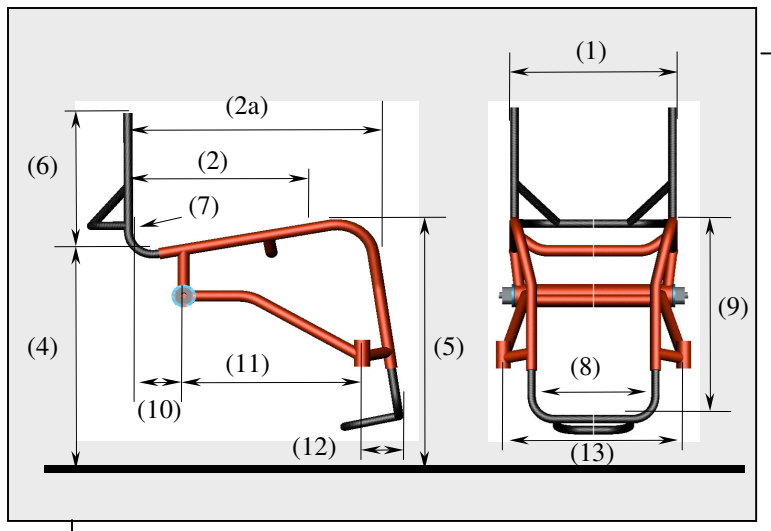

\*Effective: January 2007 Rev C.

Pricing and specifications are subject to change without notice

Customer Services: Telephone: 972-641-6773 Facsimile: 972-623-0585	<b>PER4MAX MEDICAL</b> www.per4max.com Page 1 of 2	612 N. Great Southwest Pkwy Arlington, TX 76011
--	--	--

# PER4MAX LIGHTNING

## FRAME COLORS

Sky White     Bonded Silver     Glossy Black     Safety Yellow     Red Baron  
 Candy Blue     Sparkle Green     Safety Orange     Dormant Violet  
 Accessory Colors Standard Glossy Black     Accessory Color Option \_\_\_\_\_ (one color additional: \$350)  
 Other: \_\_\_\_\_ \$TBD     Backrest     Footrest     Camber Bar     Side Guards

## WHEELCHAIR OPTIONS

<b>BACK REST</b>	
<input type="checkbox"/> Rigid .....	NC
<input type="checkbox"/> Folding .....	\$ 280
<b>PUSH HANDLES</b>	
<input type="checkbox"/> Removable .....	\$ 250
<input type="checkbox"/> Integrated .....	\$ 205
<b>SIDE GUARDS</b> (std. fixed)	
<input type="checkbox"/> Aluminum (folding backrest requires removable)...	\$ 140
<input type="checkbox"/> Removable Extra .....	\$ 90
<input type="checkbox"/> Removable Plastic .....	\$ 225
<input type="checkbox"/> Cloth .....	\$ 90
<b>WHEEL LOCKS</b>	
<input type="checkbox"/> Push Locks .....	NC
<input type="checkbox"/> Scissors Locks .....	\$ 220
<input type="checkbox"/> Top    or <input type="checkbox"/> Bottom (install)	
<b>CASTERS</b>	
<input type="checkbox"/> 3" (72mm) Micro .....	NC
<input type="checkbox"/> 4x1" Plastic .....	\$55
<input type="checkbox"/> 5x1" Plastic .....	\$65
<input type="checkbox"/> 4x1" Aluminum .....	\$ 95
<input type="checkbox"/> 5x1" Aluminum .....	\$ 100
<input type="checkbox"/> Frog Legs .....	\$ 329
<input type="checkbox"/> Other _____	\$TBD
<b>MISCELLANEOUS</b>	
<input type="checkbox"/> Swing Away Armrest .....	\$ 350
<input type="checkbox"/> Anti-Tip Bars .....	\$ 225
<input type="checkbox"/> Foam Impact Guards .....	\$ 75
<input type="checkbox"/> Nylon Pouch .....	\$ 60
<input type="checkbox"/> Plastic Foot Plate .....	\$ 80
<input type="checkbox"/> Other _____	\$TBD

## WHEELS & TIRES

<b>WHEELS</b>	
Standard Wheels .....	NC
<input type="checkbox"/> 24" STD.	
<input type="checkbox"/> 25" <input type="checkbox"/> 26" <input type="checkbox"/> 27" .....	\$300
Spinergy Wheels .....	\$ 695
<input type="checkbox"/> 24" <input type="checkbox"/> 25" <input type="checkbox"/> 26" <input type="checkbox"/> 27"	
<input type="checkbox"/> Black <input type="checkbox"/> White <input type="checkbox"/> Blue <input type="checkbox"/> Red <input type="checkbox"/> Yellow	
X-Core Wheels <input type="checkbox"/> 25" .....	\$ 780
<b>HAND RIMS SYLE</b>	
<input type="checkbox"/> Hard Anodized .....	NC
<input type="checkbox"/> Rhino Coated .....	\$ 130
<input type="checkbox"/> Foam Coated .....	\$ 190
<input type="checkbox"/> Other _____	\$TBD
<b>TIRES</b>	
<input type="checkbox"/> High Pressure Tires .....	NC
<input type="checkbox"/> KiK Mako Tires .....	\$ 110
<input type="checkbox"/> All Terrain Tires .....	\$ 100
<input type="checkbox"/> Other .....	\$TBD

Notes:

\*Effective: January 2007 Rev C.

Pricing and specifications are subject to change without notice